

# SERVICE BODY & PLATFORM WIRING DIAGRAMS & MAINTENANCE MANUAL

// SERVICE BODY, CRANE BODY, LINE BODY, KNP KAP, KNP PACK, KUV, TOOL BOX  
AND WESTERNER STORAGE BODY PRODUCTS



## // SERVICE BODY & PLATFORM MAINTENANCE INSTRUCTIONS

Proper care and maintenance of Knapheide products will assure many years of service. Follow all manufacturer's recommendations to qualify for warranty coverage. Thoroughly read and understand all of the information provided in this manual.

## // TORQUE SPECIFICATIONS

Service body to chassis mounting bolts, platform to chassis mounting bolts and shear strap bolts (vehicles under 10,000 lbs. GVWR) must be checked at regular intervals for proper torque. Reference the chart below for proper torque specifications.

TORQUE SPECIFICATIONS & INTERVALS				
PRODUCT	BOLT SIZES / TORQUE VALUE (ft. lbs. / dry threads)			INTERVALS
	3/8"	1/2"	5/8"	
Service Body	45	115	150	90 Days after vehicle is put into service and annually, or every 10,000 miles thereafter.
Platform	DNA	115	30 on U-bolts	

## // ELECTRICAL WIRING DIAGRAMS

Wiring diagrams are provided on the following pages. Body wiring harnesses are connected to the chassis wiring harness at the rear of the chassis frame. For fuse locations and ratings, refer to the chassis manufacturer's manuals and wiring diagrams.

# SERVICE BODY UNDER 80" WIDTH

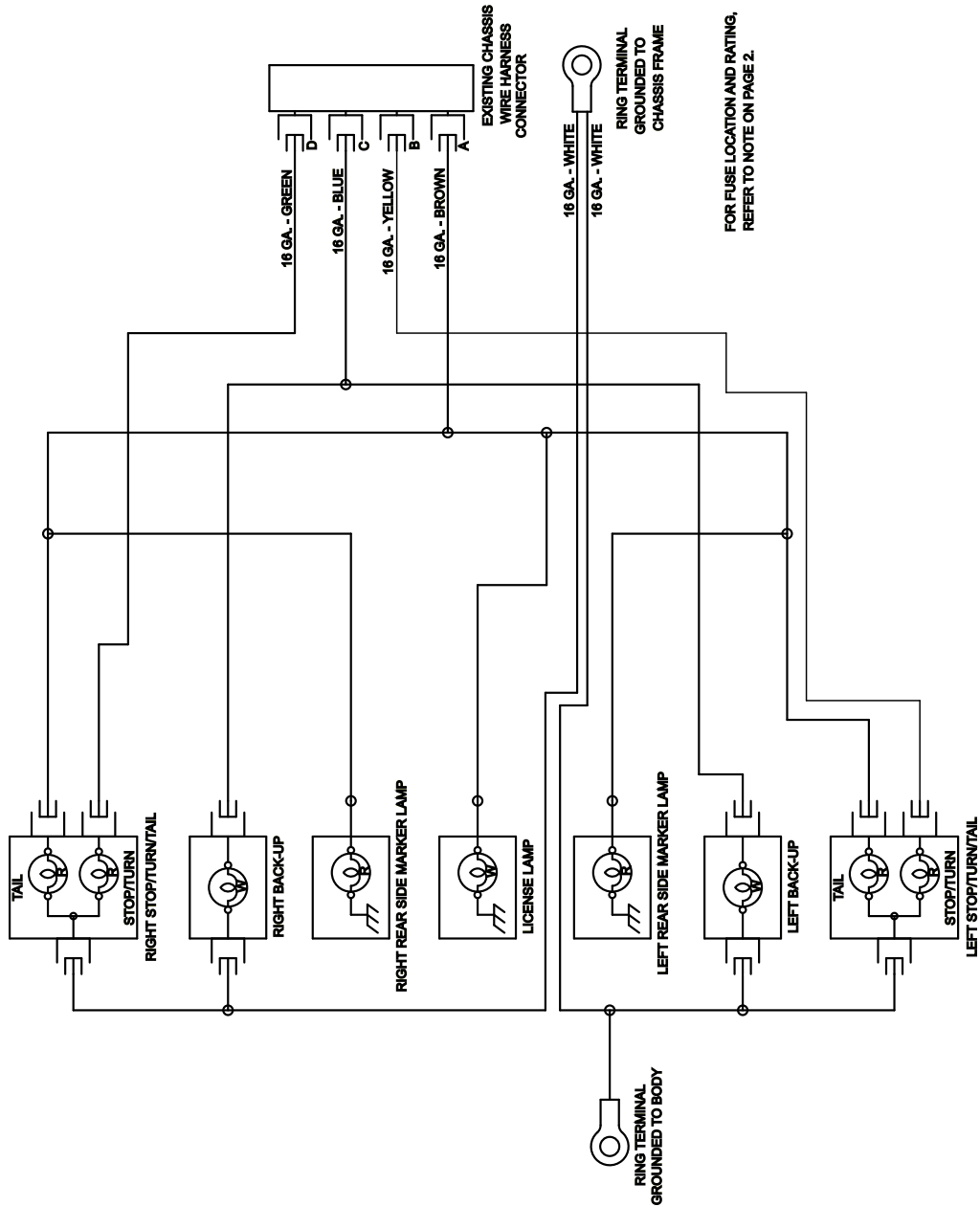

# SERVICE BODY OVER 80" WIDTH

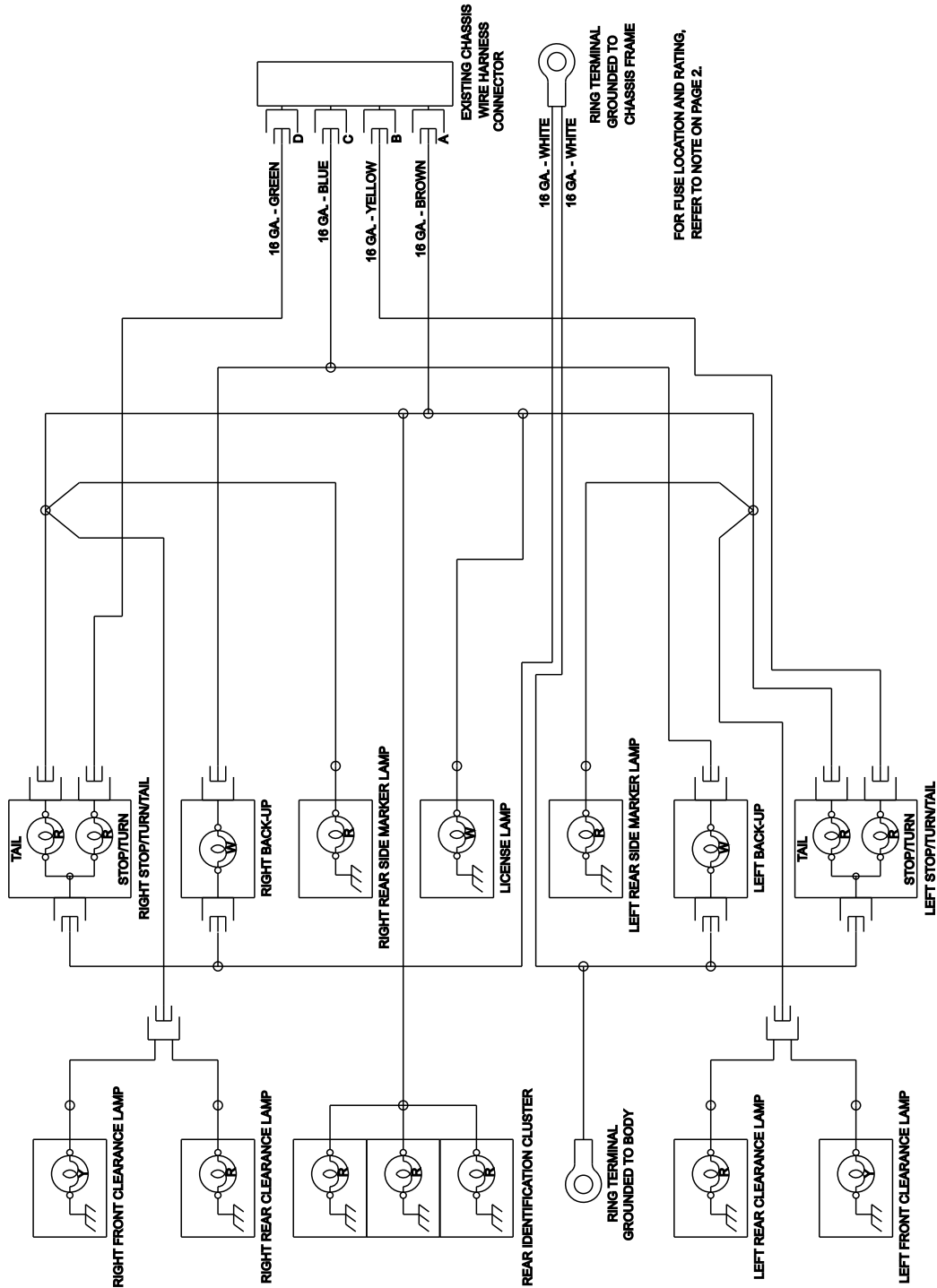

INFORMATION ON THIS PAGE MAY NOT BE REPRODUCED WITHOUT THE EXPRESS WRITTEN CONSENT OF THE KNAPHEIDE MFG. CO.

DATE: 10-14-98

PART NO. 12300265

PAGE 4 OF 8

# KUV Knapheide Utility Van

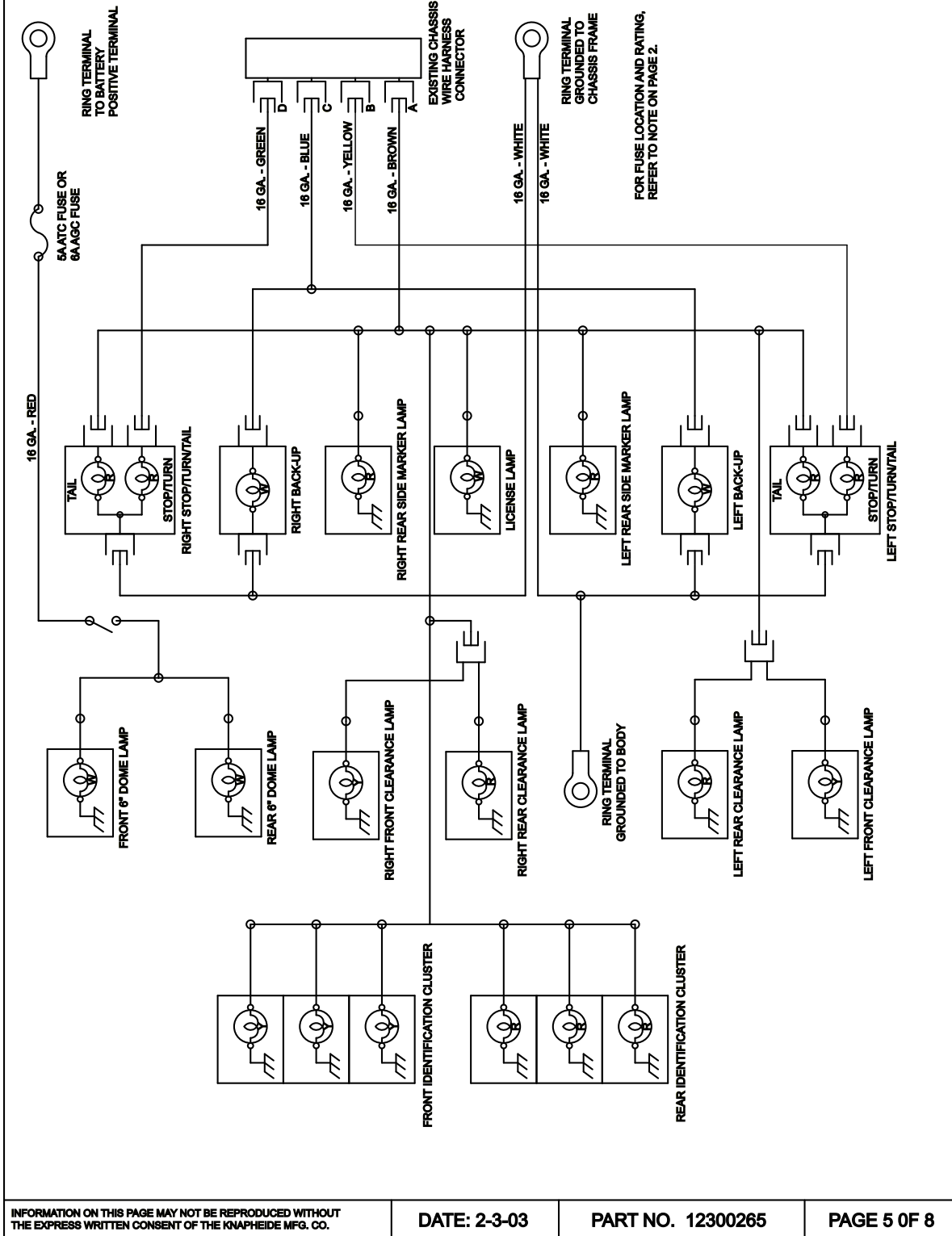

DATE: 2-3-03

PART NO. 12300265

PAGE 5 OF 8

# PX & PVMX PLATFORM 80" MODELS ON 56" CA

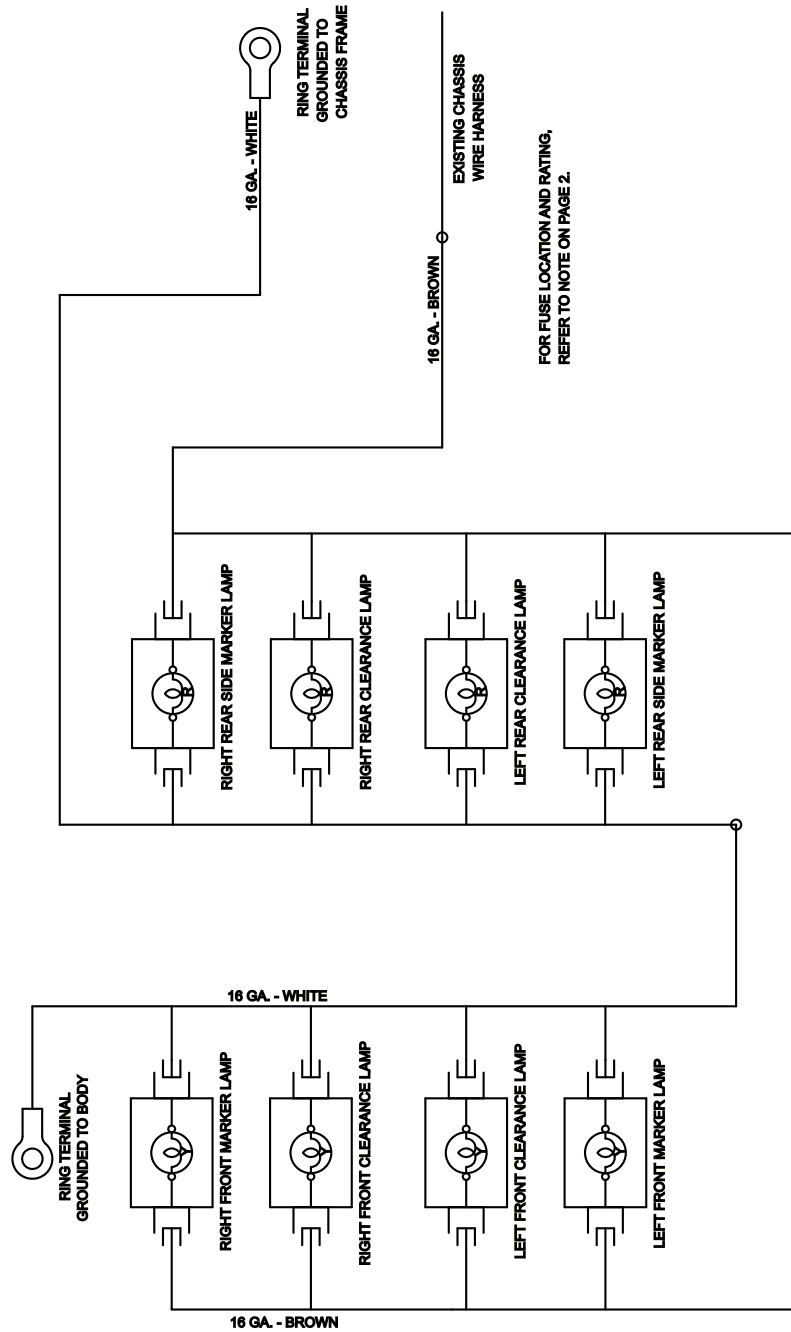

# WESTERNER PLATFORM 8 FT. MODELS ON 56" CA

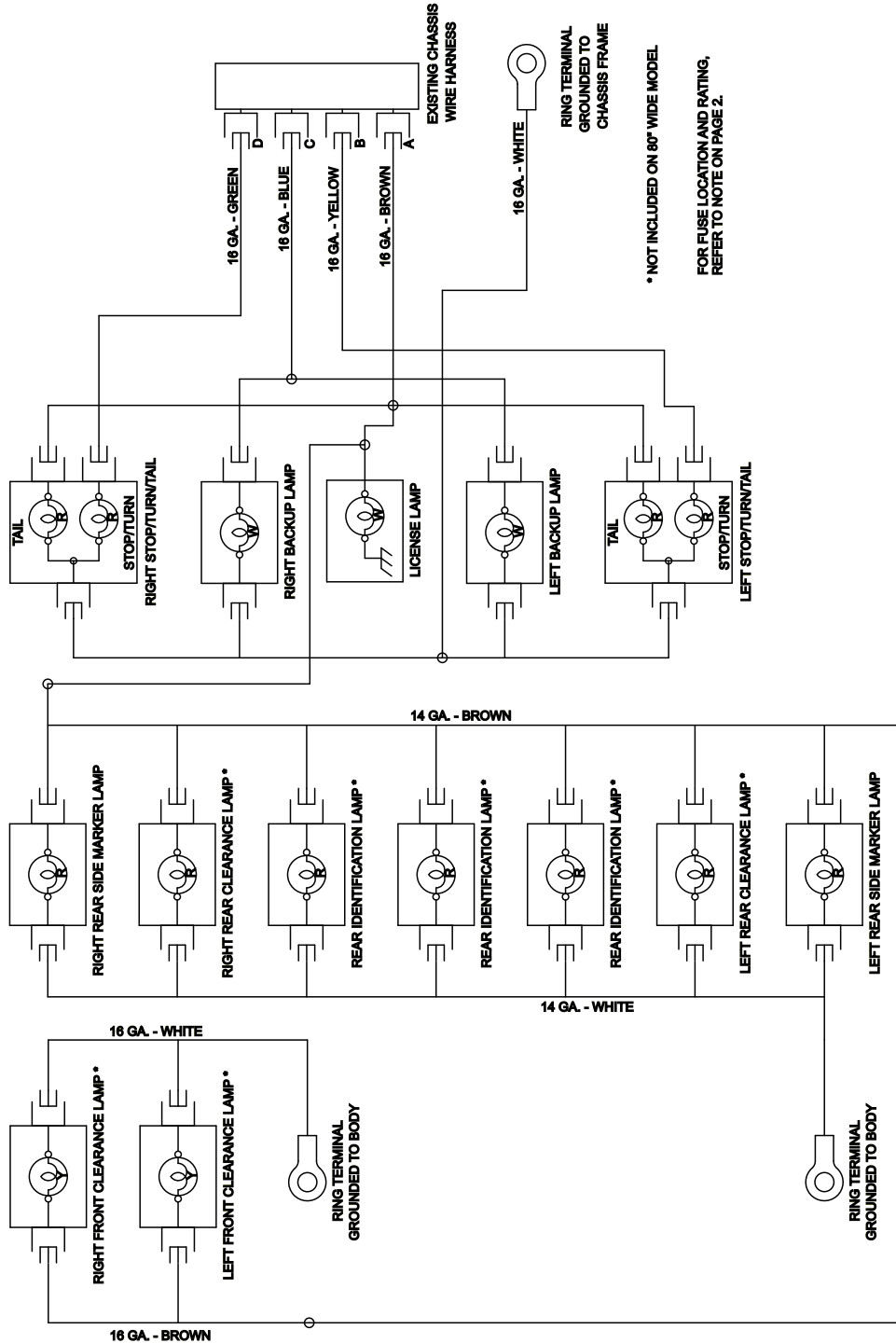

\* NOT INCLUDED ON 80" WIDE MODEL  
FOR FUSE LOCATION AND RATING,  
REFER TO NOTE ON PAGE 2.

# PLATFORM BODIES OVER 80" WIDTH

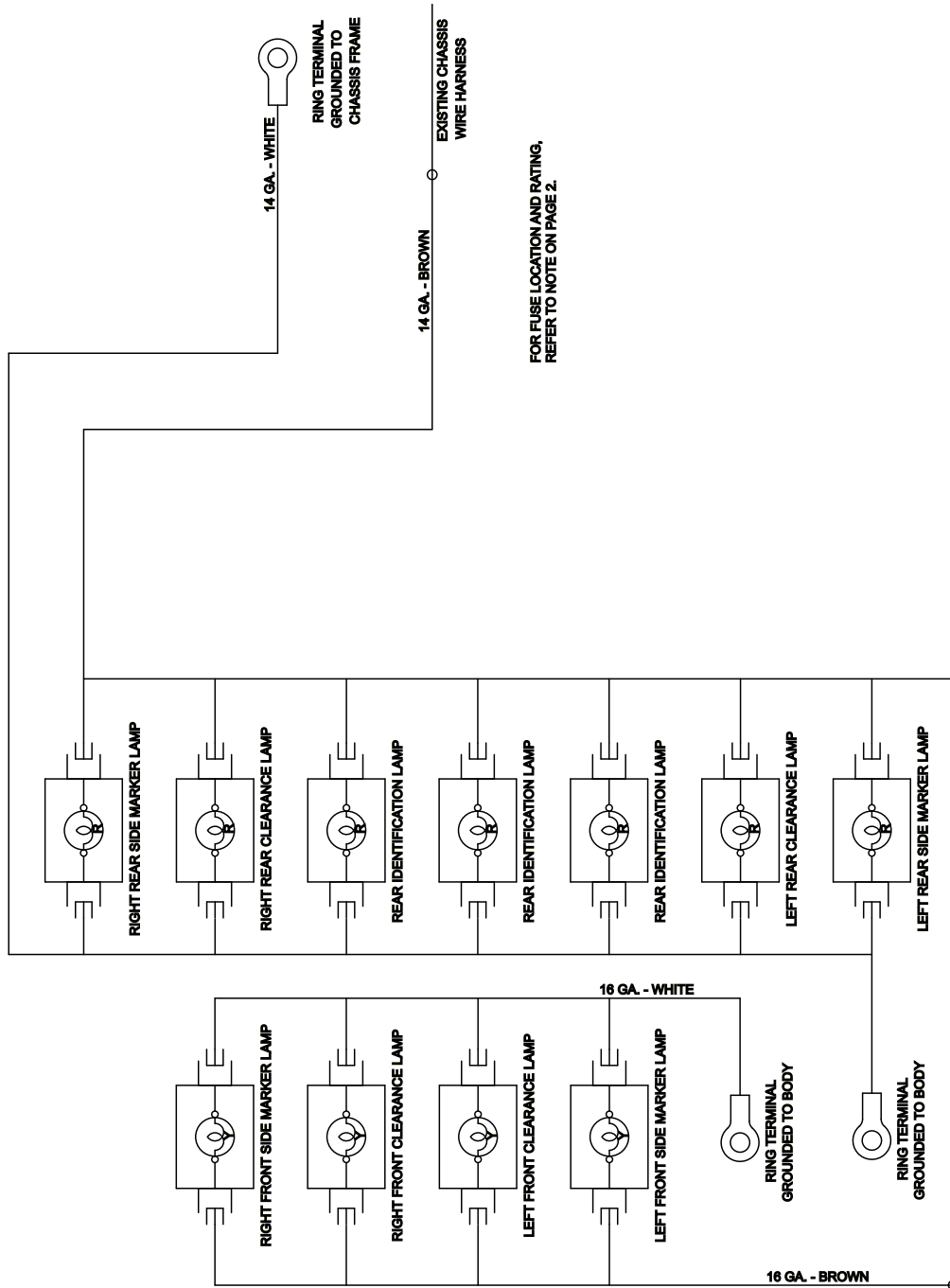

INFORMATION ON THIS PAGE MAY NOT BE REPRODUCED WITHOUT THE EXPRESS WRITTEN CONSENT OF THE KNAPEHEIDE MFG. CO.

DATE: 10-14-98

PART NO. 12300265

PAGE 8 OF 8





The Knapheide Product Support Center  
1848 Westphalia Strasse | P.O. Box 7140 | Quincy, IL 62305

P: 217-592-5233 | [productsupport@knapheide.com](mailto:productsupport@knapheide.com)

Knapheide product warranty information can be found at

<https://www.knapheide.com/files/source/knapheide/Service/Knapheide-Warranty.pdf>